

Electromagnetic Induction: An Alternative for Teaching and Understanding

Hermann Härtel

haertel@astrophysik.uni-kiel.de
Institute for Theoretical Physics and Astrophysics - ITAP
University of Kiel
Christian-Albrechts-Platz 4, 24118 Kiel, Germany

(Received: 15. 09. 2018, Accepted: 26. 10. 2018)

Abstract

The classical physics treatment of "Electromagnetic Induction" is based on Faraday's Law and Lorentz Force. This paper presents an alternative approach, based on Wilhelm Weber's Fundamental Force Law of Electrodynamics. It covers mutual induction, self-induction, parallel and anti-parallel currents, and currents in the same and opposite direction. The two approaches lead to the same quantitative results, but the conceptual difficulties are quite different. These problems are discussed in this paper, together with some consequences for teaching and classroom activities.

Keywords: Electromagnetic induction, Weber's fundamental law of Electrodynamics, Newton's 3rd law, self-induction, mutual induction

Foreword

It is often simpler to write about a topic in a way that is consistent with conventional physical knowledge than in a way that challenges well-known ideas or presents alternatives to those ideas. Is there an alternative to such well-accepted science as Faraday's Law and Lorentz Force? The answer is yes. Moreover, this alternative has advantages, discussed below, especially didactical ones. Readers may decide to what extent the law developed by Wilhelm Weber satisfies this promise.

STARTING POSITION

Traditional Procedure

Inspired by Oersted's discovery in 1819 that a magnetic needle is affected by an electric current, Faraday and Ampère in particular began to investigate this effect. In 1831 Faraday formulated his results in the form of the law named after him, which connects the generation of an electric field to the change of magnetic flux with respect to a surface and its surroundings (Faraday, 1832).

This work established that the change in the magnetic flux is crucial for the determination of induced electric fields or induced electric currents. A change of magnetic flux through a given area may be caused by movement of macroscopic objects within a constant magnetic field, or by variation of the electric current in a circuit which is generating the magnetic field. School physics recognizes this by considering motional induction and field induction. As a rule, one differentiates,

- *Electric Coulomb forces - caused by separate stationary charges;*
- *Magnetic forces (Lorentz force) - caused by moving charges in a magnetic field;*
- *Non-coulombic electrical forces - caused by changing magnetic fields, or more precisely, by changing magnetic flux with respect to a certain area.*

In this context, Feynman writes: (Feynman, 1964)

"We know of no other place in physics where such a simple and accurate general principle requires for its real understanding an analysis in terms of two different phenomena."

What is being referred here is Faraday's Law and the Lorentz Force, which are both needed to describe the phenomena of induction. This statement is contradicted by claiming that Faraday's law is a general law, valid also for those cases mentioned by Feynman. The claim is that it is important to accept that the appearance of induction is not bound to the existence of a conductor. A circular electric field is induced along any path where inside of it the magnetic flux is changing.

Procedure According to Weber

Ampère, and later Weber, took a different route. From the start of his work, Ampère interpreted all magnetic phenomena as being caused by electrical currents. In 1820 he published some early thoughts on a law of force (Ampère, 1820). In 1822 he published the final version of this law, which describes the interaction between two current elements randomly arranged in space (Ampère, 1822). Weber followed this approach while trying to find a basic law of electrodynamics and, in 1846, presented such a law of force from which both Faraday's Law and Ampère's Law of force could be deduced (Weber, 1846).

In Ampère and Weber's approach magnetic fields do not occur. Instead, only direct interactions between charge carriers are assumed. In other words, only attractive or repulsive forces along the connecting line of the interacting partners exist. Weber's force equation represents an extended Coulomb force, describing the interaction between two-point charges q_1 and q_2 . There are two additive elements; the first contains the factor $-v^2/c^2$, the second the factor $+a/c^2$. Weber's fundamental law describes the mutual force $F_{1 \rightarrow 2}$ (force of q_1 on q_2) and $F_{2 \rightarrow 1}$ (force of q_2 on q_1) between two charge carriers q_1 on q_2 separated by a distance r .

The law reads as follows:

$$\vec{F}_{1 \rightarrow 2} = \frac{q_1 q_2 r_{12}^0}{4\pi\epsilon_0 r_{12}^2} \left(1 - \frac{\vec{v}_{12}^2}{2c^2} + \frac{\vec{r}_{12} \vec{a}_{12}}{c^2} \right) = -\vec{F}_{2 \rightarrow 1}$$

The terms v_{12} and a_{12} denote the relative velocity dr/dt and the relative acceleration d^2r/dt^2 between the interacting partners. r_{12}^0 denotes a unit vector in the direction from q_1 to q_2 . The constant c , first introduced by Weber, was later experimentally determined by him and Kohlrausch as matching in dimension and size the speed of light (Weber, Kohlrausch, 1856). It follows that all changes that result from Weber's law compared to Coulomb's law are very small and therefore comparable in magnitude to the usual magnetic effects.

In the following we will show how it is possible to explain on the basis of Weber's law the phenomena "Faraday's Law", "motional emf", and "interaction between parallel current-carrying conductors". An explanation of the topic "unipolar induction" will be reserved for an upcoming paper. In this first approach only, qualitative methods and arguments are used. For a deeper quantitative analysis reference is made to the corresponding publications.

FARADAY'S LAW

Traditional Procedure

Mutual Induction

Both, Faraday and Joseph Henry in America established a relationship between a magnetic flux change with respect to a certain area and an induced circular electric field along the edge of this area or, where appropriate, an electric current induced there.

Typically, in a course on this topic, the current induced in a secondary coil is demonstrated by the removal or approach of a permanent magnet, by the insertion or removal of an iron core into a current-carrying coil, or by the on-/off switching of the current through the primary coil.

Self-Induction

The fact that a current loop or a coil has as a special property called inductivity is usually addressed when circuits are treated with active elements, such as in circuits for generating electrical oscillations. Under strict application of Faraday's law, the self-inductance of a coil readily follows. If the magnetic flux inside an area changes, a circular electric field is induced along the edge of this area.

The self-induction is thus an interaction by means of a magnetic field between the flowing electrons themselves. This gives rise to a didactically problematic idea: that an electric current produces an effect (the changing magnetic field), that hinders it, somewhat like an inertia acting on itself; this difficulty is usually not discussed in textbooks.

The simplicity of the mathematical form of this law is impressive. However, a problem remains, especially in didactic terms - the lack of a more in-depth explanation for the relationship between the rate of change of the magnetic flux through an area and the induced non-coulombic electrical force along the border of this area. This lack of a more in-depth explanation as a didactic problem is rarely discussed in textbooks (Chabay, Sherwood, 2002), which may be one reason why even good students after intensive instruction find it difficult to apply their acquired knowledge to previously unseen induction tasks (Zusa et al. 2016).

Procedure According to Weber

Self-Induction

Magnetic fields are irrelevant in Weber's world. Thus, it is easy to conclude that at the beginning of a course on the subject of induction the phenomenon of self-induction should be introduced. As will be shown, this topic reveals a major difference in the description, and explanation of this phenomenon compared to standard theory. Consider first a section of homogeneous straight conductor with an equal number of stationary positive lattice building blocks and the same number of free electrons per unit length as part of a larger closed circuit (Figure 1). For the sake of simplicity, it is assumed that by applying an external voltage all free electrons undergo a uniform acceleration starting from rest.

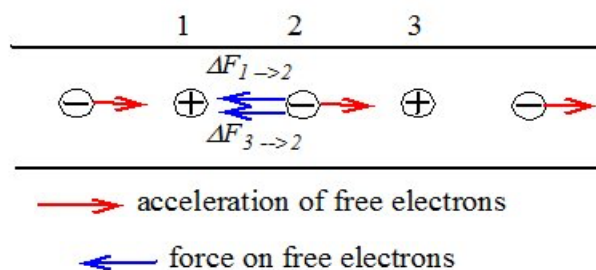

Figure 1. Section of a conductor (see text).

Consider now the interaction between the positive lattice unit 1 and the accelerated electron 2. The acceleration is seen from 1 as positive (the distance is increasing, when starting from rest), and thus from Weber's equation only the acceleration term is relevant. This leads to an increase of the attractive force between 1 and 2 equal to $F_{1 \rightarrow 2}$.

Consider now the interaction between the positive lattice unit 3 and the accelerated electron 2, whose acceleration is negative when seen from 3 (the distance is decreasing). It follows that, according to the acceleration term in Weber's equation, the attractive force between 3 and 2 is

reduced. Since the repulsive interaction between all other charge carriers remains the same, this reduction means for the accelerated electron 2 another ΔF in the direction opposite to the developing current. Thus, in total some kind of inertia results as a dual effect of the acceleration term of Weber's equation of force.

This kind of inertia is additionally dependent on the position of the returning conductor parts of the relevant electric circuit. The charge carriers of these parts are also subject to Weber's interaction. Depending on the distance between the forward and the return lines and due to the opposing acceleration of the free electrons within these return parts, the hindrance is reduced to some extent. A circuit consisting of twisted conductors has practically no inductance. Demonstration of quantitative agreement with the experiment that follows from these qualitative considerations, can be found in (Assis, 1997).

In summary, there is an important difference in this area between Weber's electrodynamics and traditional electromagnetism. According to Weber, self-induction results from an interaction between free electrons and positive lattice components of the same circuit. In the traditional understanding, however, self-induction is interpreted as an interaction between the free electrons with themselves - by means of a self-generated magnetic field.

In quantitative terms, there are no differences, while in didactic terms, there is a clear difference of clarity and understanding.

Mutual Induction

We consider first two sections of two separate closed circuits, a primary circuit P and a secondary circuit S with the same amount of positive lattice units and free electrons per unit-length (Figure 2). For the sake of simplicity, it is assumed that by applying an external voltage to the circuit P, all free electrons of this circuit P are uniformly accelerated from rest

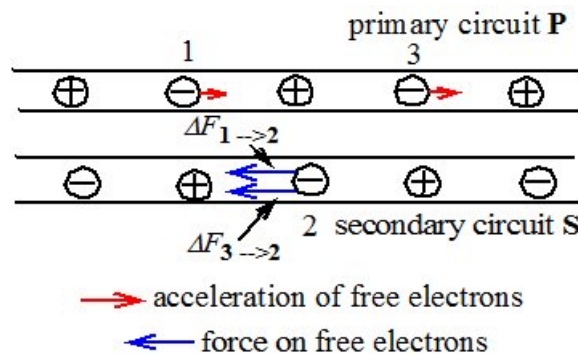

Figure 2. Section of two separate conductors with accelerated electrons in P (see text).

We consider now the force from the accelerated electron 1 of circuit P acting on the initially stationary electron 2 of circuit S. The acceleration, as seen from electron 2 in S, is negative (the distance is reduced), and thus Weber's equation results in a reduction of the repulsive interaction between 1 and 2.

Since the interaction with all neighboring conductor elements is not changed, this reduction implies an accelerating force $F_{1->2}$ against the direction of the accelerating electrons in the primary circuit. If we now consider the interaction between the accelerated electron 3 in the primary circuit and the initially stationary electron 2 in the secondary circuit, then this acceleration is positive as seen from 2 (the distance increases) and, according to Weber, this results in an increase of the repulsive force between 3 and 2 = $F_{3->2}$. For the electron on which we have focused - and this consideration can be applied to all electrons of the secondary circuit - these two changed interactions add to give an accelerating force against the direction of the developing flow in the primary circuit, which thus creates an induced current. For a quantitative treatment, reference should again be made to the literature (Assis, 1997).

MOTIONAL EMF

Traditional Procedure

In a traditional course, experiments are commonly used to demonstrate how a voltage, or an electric current can be induced by the relative movement of a coil and a permanent magnet. If the coil in Figure 3 is moved relative to the laboratory and to the permanent magnet, the Lorentz force explains the induction of voltage or current.

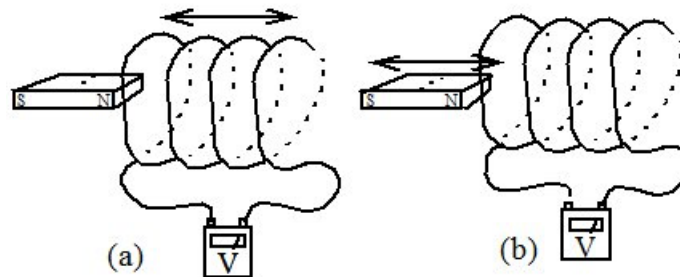

Figure 3. (a) Interpretation of induction as caused by a Lorentz force.
(b) Interpretation of induction as caused by a changing magnetic flux.

If the permanent magnet is moved relative to the laboratory and relative to the coil, only Faraday's Law provides an explanation of this observation. However, these two cases represent always the same experiment: a relative movement between the coil and the permanent magnet. The experiments shown in figure 3 are usually analyzed based on simple experimental setups where the permanent magnet is reduced to a constant magnetic field and the coil is either rotated in a magnetic field or is reduced to a linear conductor sliding on a fixed frame perpendicular to the magnetic field lines (Figure 4)

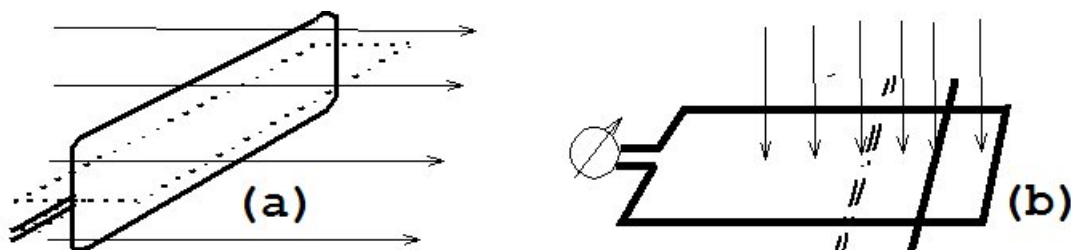

Figure 4. (a) Induction by rotating a conductor loop
(b) Induction by moving a conductor element (both within a constant magnetic field).

Procedure According to Weber

To explain motional emf based on Weber's approach, a special rule, well known in classical physics, is needed. The rule is: Parallel current-carrying conductors either attract or repel each other depending on the direction of the current's drift velocity. In the following section it will be shown how this rule can be derived from Weber's law. Figure 5(a) shows a metallic bar moving in a direction perpendicular to the field lines of a permanent magnet. In agreement with Ampère's approach, the phenomenon of a magnetic field is treated by Weber as being evoked inside of a current carrying circuit (shown in figure 5(b) in the form of a rectangle for clarity). A linear conductor moving within this circular current represents a current of negative and positive charge carriers in the +x-direction.

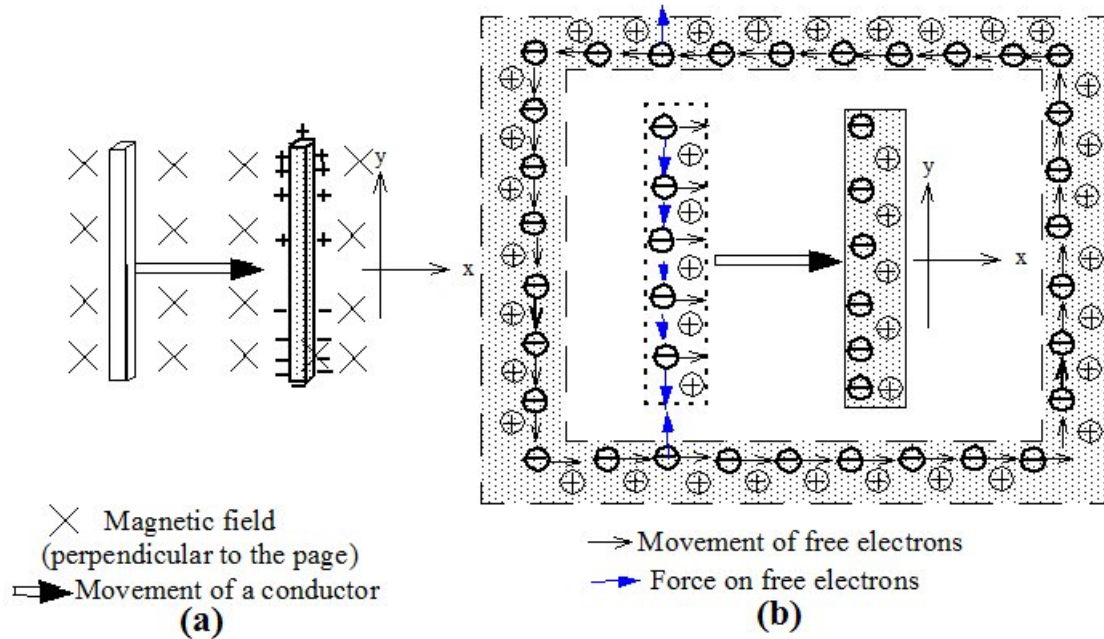

Figure 5. (a) Induction through movement of a conductor within a magnetic field
(b) Induction due to the rule: anti-parallel moving charge carriers repel each other, parallel moving charge carriers attract each other

According to the rule: parallel currents attract each other, antiparallel currents repel each other; there is a force on these charge carriers in the positive or negative y -direction, depending of the polarity. As a result of this rule, there is a shift of the free electrons (the positive lattice elements of course cannot be moved). If the linear conductor is electrically connected to a metallic frame, an induced circulating current results in the fixed frame plus linear conductor (Figure 6).

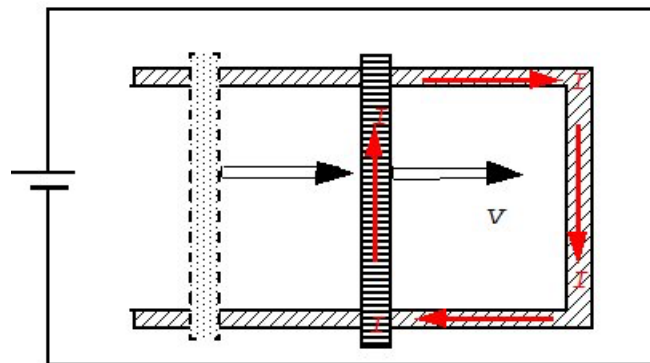

Figure 6. Induced circular current due to the movement of the bar, electrically connected to the metallic frame.

INTERACTION BETWEEN PARALLEL CURRENT-CARRYING CONDUCTORS WITH CURRENTS FLOWING IN THE PARALLEL/ANTI-PARALLEL DIRECTION OR IN THE SAME/OPPOSITE DIRECTION

This topic clearly illustrates a difference between the traditional procedure and the procedure according to Weber.

Traditional Procedure

Currents Flowing in Parallel or Anti-parallel Direction

Based on the corresponding experiments with parallel oriented flexible current-carrying conductors, the magnetic field lines and the magnetic force (proportional to $v \times B$) are used to explain the attraction or repulsion of these conductors, depending on the direction of the current. Result: Parallel current-carrying conductors attract each other if the currents flow in the same direction and repel with anti-parallel directed currents.

Currents Flowing in the Same/Opposite Direction

The question of whether there is an interaction between the individual elements of a linear current-carrying conductor or between two separate conductors with currents flowing in the same direction does usually not arise. With solid metallic conductors such an interaction is not readily ascertainable. In addition, the magnetic field of a moving charge is exactly zero along the flow direction. Thus, a possible interaction could not be explained via a magnetic force.

However, it is known that current-carrying circuits have the tendency to extend. This can be explained by the rule that in a closed circuit all parts with currents flowing in anti-parallel direction do repel each other (see Figure 7).

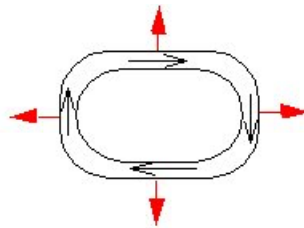

Figure 7. Magnetic forces between opposite circuit elements.

Therefore, there should be a certain longitudinal stress present in all current carrying circuits. As will be shown, Weber and Ampère gave totally different explanations by stating that there exists a repulsion between two portions of the same current or between two sections of two currents in separate conductors flowing in the same direction.

There are no statements in the frame of classical physics about a possible interaction between current elements of two separate conductors, flowing in opposite directions. As will be shown, there is once again a clear difference between classical physics and the approach of Weber and Ampère.

Procedure According to Weber

Interaction Between Current Elements Flowing in Parallel/Anti-Parallel Directions

(A) Parallel Direction of Interacting Current Elements

Assuming two parallel conductors (1) and (2) of the same cross-section with currents of equal strength, flowing in the same direction, there are no relative velocities between the negative charge carriers of the two conductors; the same holds of course for the stationary positive lattice components. However, there will be a relative velocity between the negative and the positive charge carriers of any two elements of the two conductors.

If we select a negative element A of conductor (1) as reference, the drift velocity of the positive elements of conductor (2) relative to the laboratory and the velocities relative to A are displayed in Figure 8.

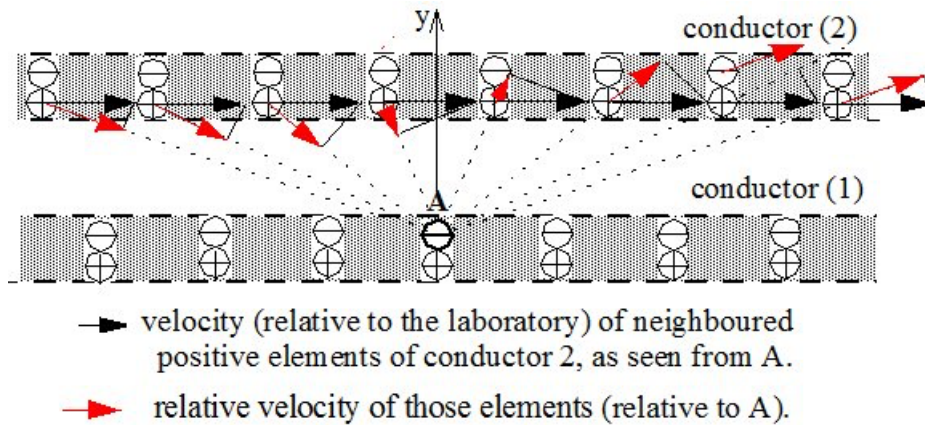

Figure 8. Drift velocity of lattice elements of conductor (2) relative to the laboratory and relative velocity between the negative element A of conductor (1) and positive elements of conductor (2)

If the relative velocities are copied from Figure 8 to Figure 9 and transferred to a v/x -diagram, the slope of the v/x -curve is shown as always positive with a maximum for $v_{rel}=0$.

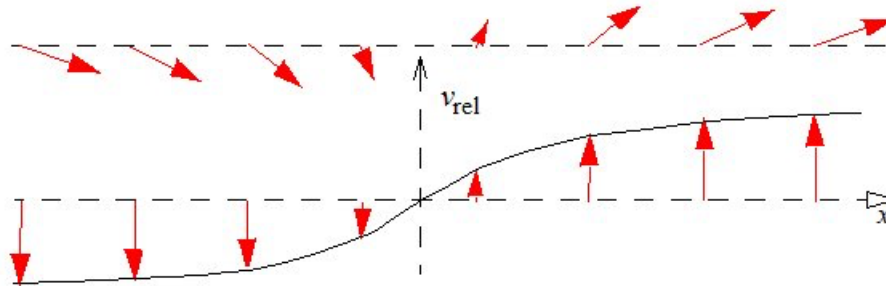

Figure 9. The relative velocities taken from figure 8 and transferred to a v/x -diagram.

This curve corresponds to the relative acceleration between the passing charge carriers and element A and can be applied to all other elements of conductor 1. This result may surprise at first because of the constant drift velocity, but it follows from the fact that a movement of two interacting particles without relative acceleration is only possible if a particle moves on a circular path with the second particle as the center. For a movement on a straight line, however, there is an outward oriented relative acceleration.

Even though the involved velocity components are symmetrical according to their sign, the corresponding velocity terms of Weber's equation do not cancel since the velocities have to be squared. The integration over all velocity and acceleration components gives as result, that the positive acceleration term dominates the negative velocity term by a factor 3. To establish this difference, mathematical methods are necessary.

Due to this dominant positive acceleration term, and since the other interactions remain unchanged, it follows, as expected, from Weber's equation an attracting force between two conductors with currents drifting in parallel directions.

(B) Anti-Parallel Direction of Interacting Current Elements

In case of anti-parallel currents, the positive and the negative portions of conductor 2 move with different relative drift velocities as seen from the element A. However, the larger relative velocity of the negative elements dominates and leads finally, as expected, to an increase of the repelling interaction between parallel conductors with currents flowing in anti-parallel directions.

Interaction between Current Elements Flowing in the Same/Opposite Direction

(A) Same Direction of Interacting Current Elements

When considering two elements dI_1 and dI_2 of a linear conductor, consisting of an equal number of positive and negative charge carriers, in general there are four interactions between element dI_1 and element dI_2 to be considered (Figure 10):

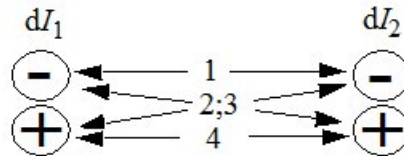

Figure 10. Interactions between two current elements

1. The repelling interaction between the negative component of element dI_1 and the negative component of element dI_2 .
2. The attracting interaction between the negative component of element dI_1 and the positive component of element dI_2 .
3. The attracting interaction between the positive component of element dI_1 and the negative component of element dI_2 .
4. The repelling interaction between the positive component of element dI_1 and the positive component of element dI_2 .

With no current flowing and therefore no relative velocity (and no relative acceleration) the interactions 1 and 2 and the interaction 3 and 4 cancel each other. With constant currents and assuming the same drift velocity in the same direction (Figure 11) there is no relative velocity (and no relative acceleration) between the negative components of the two conductors; the same holds for the positive components of the two conductors.

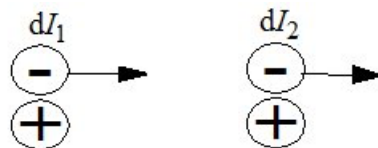

Figure 11. Two current elements with equal currents flowing in same direction.

Therefore, the interactions 1 and 4 will not change while the interactions 2 and 3 will change since there is a relative velocity between these interacting partners, when looking either from the negative component of dI_1 or of dI_2 .

In Weber's Equation of Force, applied to this case with $a=0$, we obtain:

$$\vec{F}_{1>2} = \frac{q_1 q_2 \hat{r}_{12}}{4\pi\epsilon_0 r_{12}^2} \left(1 - \frac{v_{12}^2}{2c^2} \right) = -\vec{F}_{2>1}$$

The attractive interactions 2 and 3 (see Figure 10) are both reduced by a small amount. Thus, the unchanged repulsion between the negative and the positive components respectively of the two current elements (interactions 1 and 4) dominates and there is an overall repulsion between all two current elements flowing in the same direction.

Ampère demonstrated this effect experimentally in his eponymous bridge experiment, in 1822 (Ampère, 1822) (Figure 12).

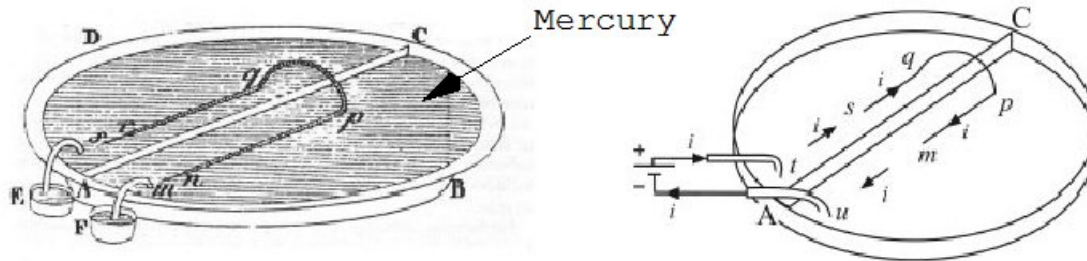

Figure 12. Ampère's bridge experiment. The illustration shows the current flow and indicates the movement of the bridge element *sqpm* (Assis,2015).

A German textbook dating from 1958 shows the same experiment (Figure 13), this time according to the prevailing opinion to demonstrate the repulsion of anti-parallel current elements, in this case the bridge element and the battery part (Bergmann-Schaefer, 1958).

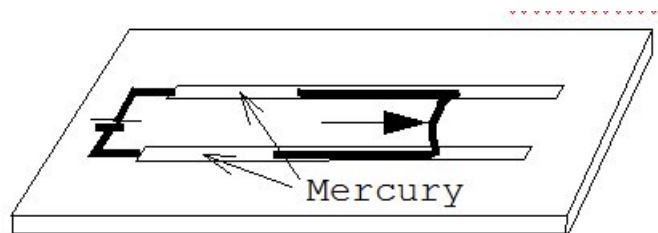

Figure 13. Experiment to prove the expanding effects of magnetic forces on electric circuits.

(B) Opposite direction of interacting current elements.

If we have two current elements of two separate conductors with an equal constant current flowing in opposite directions, one of which is taken as reference, there will be a relative velocity between the two negative components which is twice as large as the relative velocity between the components of opposite charge for either dI_1 or dI_2 as reference (Figure14).

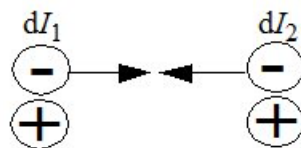

Figure 14. Two current elements of two different circuits with equal currents flowing in opposite direction.

The latter (interactions 2 and 3 of Figure 10) is reduced due to the velocity term of Weber's equation by a certain amount while the former (interaction 1) is reduced by 4 times this amount (velocity term proportional to v^2). Since there is no relative velocity between the two positive components of dI_1 and dI_2 , interaction 4 will not change. The addition of all these changes results in a reduction of the two repulsive interactions (1+4) which is twice as large as the reduction of the two attractive interactions (2+3). *Final result:* Attraction between current elements, flowing in opposite direction.

Summary

The following 4 rules apply to Weber's and to Ampère's electrodynamics:

1. *Parallel oriented current elements attract each other:*



2. *Anti-parallel oriented current elements repel each other:*



3. *Current elements flowing in the same direction repel each other:*



4. *Current elements flowing in opposite directions attract each other:*



Rules 1 and 2 are known in traditional physics. As already mentioned, rule 3 can be deduced from the fact that a current-carrying circuit tends to expand. This could be interpreted as caused by a repulsion between the current elements flowing in the same direction. Completely new is rule 4. Since electric currents have no magnetic field in their current direction, no statement can be made here on the base of magnetic forces.

CONCLUSION

About the traditional theory

The prevailing theory of induction, based on Faraday's Law and Lorentz Force, faces the following problems of understanding:

1. *The question of why two different descriptions (flux law and Lorentz force) are needed to describe a single phenomenon is unanswered or at best is controversial.*
2. *A mechanism behind the Lorentz force that explains how a magnetic field can cause a force perpendicular to the motion of a charge carrier cannot be stated.*
3. *A mechanism explaining why a change in the magnetic flux through a given area causes a circular electric field along the edge of that area cannot be given.*
4. *The question of why under certain conditions a change in the magnetic flux through an area due to the movement of a conductor causes the same induction effect as a corresponding change in the intensity of the current, cannot be answered.*

From a didactic point of view, these discrepancies mean that the topics "Faraday's Law" and "Lorentz Force" are not well suited to convey a deeper understanding of the physical world. A deeper reflection is not rewarded, complexity is not reduced, but incomprehensible rules remain that have to be applied correctly. Such topics are less likely to produce subjective successful learning experiences and can lead students to become demotivated and potentially turn away from physics.

To Weber's Theory

To appreciate Weber's force law, on the other hand, one needs only to accept that the traditional Coulomb law, which applies to stationary charge distributions, must be extended. According to Weber, the Coulomb force (in itself a strange and astonishing phenomenon) depends not only on the distance of the interacting partners, but also on their relative velocity

and relative acceleration. The central feature of the Coulomb force remains: that there are only attractive or repulsive forces, acting in the direction of the line connecting the interacting partners.

In dealing with Weber's approach, the key challenge for students is learning to think in relative terms. This is not a trivial task, requiring concentration and the ability to mentally move into another system and view the world from there. Such ability is an important element of thinking as a physicist. The time required to practice this skill is an investment in good physics education. In contrast to the classical method, a more intensive study of Weber's approach is rewarded by a growing understanding. All phenomena can be traced back to the basic assumptions related to Weber's Equation of Force. The consequent reduction in complexity is a step towards successful learning and a positive attitude toward physics.

A point worthy of discussion in connection with Weber's equation is the question of forces, acting at a distance or through fields. Especially when considering electricity, the latter are regarded as the actual laws of nature, while the former have become worthless.

When Weber was active, it was generally agreed that space was filled with an ether. Since Weber did not have any specific knowledge about this ether, he could not say anything about how changing interactions are mediated between the respective interacting partners. To assume that in Weber's thoughts this mediation would happen spontaneously, that is, with infinite speed, is unreasonable. It was Weber who first set up the telegraph equation and predicted that current/voltage changes would occur along a resistance-free wire at the speed of light. Between the propagation of current/voltage changes along a wire with $R = 0$ and the propagation of electromagnetic signals through empty space, there is a gap. This gap still needs to be closed.

CONSEQUENCES FOR TEACHING AND CLASSROOM ACTIVITIES

Without changes in the curriculum, textbooks and teacher training, it is hardly possible for an individual teacher to teach anything other than the traditional approach to "Induction". What could change is the "spirit" in which this content is conveyed. Is Faraday's Law a fundamental law of nature, which should not be questioned, or is it a rather strange rule that more or less astonishingly delivers the right results, even if nobody knows why?

Does the Lorentz Force describe a process that happens exactly the same way in nature, or is this just another strange rule to marvel at, that works so well but without clear justification? Such a "spirit" would prevent students from trying to look for a deeper understanding of the phenomenon "induction" and, following probable failure, could lead to a loss of interest in further learning. Maybe there is the opportunity to introduce those students who want to understand more deeply, into Weber's world, using additional hours.

REFERENCES

- Ampère, A.M. (1820). Mémoire sur l'expression analytique des attractions et répulsions des courans électriques. *Annales de Mines* 5, pp. 546–553.
- Ampère A.-M. (1822) "Mémoire sur la Détermination de la formule qui représente l'action mutuelle de deux portions infiniment petites de conducteurs voltaïques." *Annales de Chimie et de Physique* 20, pp. 398-421.
- Assis A.K.T. (1997). Circuit theory in Weber's electrodynamics, *European Journal of Physics* 18(3), pp. 241-246.
- Bergmann, L. Schaefer, Cl. (1958). *Lehrbuch der Experimentalphysik*, De Gruyter, Berlin, Bd.2, 3.Auflage, pp. 227.
- Chabay, R., Sherwood, B. (2002). *Matter & Interaction (Vol.2)*. John Wiley.
- Faraday, M. (1832). On the induction of electrical currents. *Phil. Trans. Roy. Soc.*, pp. 125-162.

- Feynman, R. P., Leighton, R. B., & Sands, M. L. (1964). *The Feynman Lectures on Physics: Electromagnetism and matter (Vol. 2)*. Addison-Wesley Publishing Company.
- Weber W. (1846). *Elektrodynamische Maassbestimmungen - Über ein allgemeines Grundgesetz der elektrischen Wirkung*. Reprint in: *Wilhelm Weber's Werke, Vol. 3, H. Weber (ed.)*. Springer, Berlin, pp. 25-214.
- Weber, W. and Kohlrausch, R. (1856), Über die Elektrizitätsmenge, welche bei galvanischen Strömen durch den Querschnitt der Kette fließt. *Annalen der Physik*, 99, pp. 10-25, in *Wilhelm Weber's Werke*, vol. III, Weber, H. ed., Berlin: Springer, 1893, pp. 597-608.
- Zuza, K., De Cock, M., van Kampen, P., Bollen, L., & Guisasola, J. (2016). University students' understanding of the electromotive force concept in the context of electromagnetic induction. *European Journal of Physics*, 37 (6).